



F210 Donut Loadcell

F210 Donut Loadcell. Geometry: Axial strain cylinder in a sealed case, with raised end load bearing faces and hole right through. For use in compression or in fail-safe tensile applications.

The F210 is ideally suited to engineering force measurements including through centre safety testing of cables, rods and bolts.

It is designed for easy installation, usually between two flat faces bearing on its loading rings, either unattached or with retaining spigots positioned in the centre hole. Alternatively tensile load transfer can be achieved via a tie rod assembly through the centre hole. In this way the loadcell can indirectly measure tensile loads in a "fail-safe" mode.

We are happy to design variants of this loadcell to meet your specific requirements. Versions can be manufactured for fully compensated operation up to +250°C. Please consult our engineering department.

Features

- ✓ Hardened stainless steel body
- ✓ Very high structural load limit
- ✓ Standard 1 year warranty
- ✓ Tensile applications are 'fail-safe'
- ✓ Sealed to IP65
- ✓ Traceable calibration with certificate included in the standard price

Outline

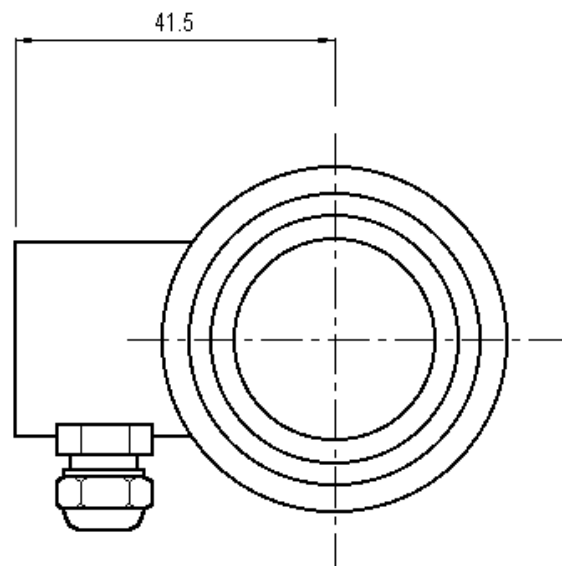
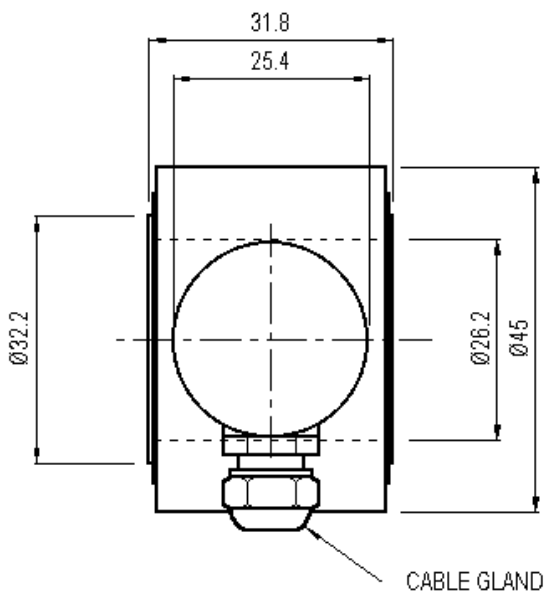

Specifications

Parameter	Value	Unit
Non-linearity - Terminal	±0.5	% RL
Hysteresis	±0.5	% RL
Creep - 20 minutes	±0.05	% AL
Repeatability	±0.02	% RL
Rated output - Nominal	1.2	mV/V
Rated output - Rationalised	1.0	mV/V
Rationalisation tolerance	±0.5	% RL
Zero load output	±4	% RL
Temperature effect on rated output per °C	±0.005	% AL
Temperature effect on zero load output per °C	±0.03	% RL
Temperature range - Compensated	-10 to +50	°C
Temperature range - Safe	-10 to +80	°C
Excitation voltage - Recommended	10	V
Excitation voltage - Maximum	20	V
Bridge resistance	700	Ω
Insulation resistance - Minimum at 50Vdc	500	MΩ
Overload - Safe	50	% RL
Overload - Ultimate	400	% RL
Sealing	IP65	
Weight - Nominal (excluding cable)	240 to 280	g

Order Codes

Code	Description
F210CFR0K0	Compression, IP65, unrationalised
F210CFR0KN	Compression, IP65, rationalised

Structural Stiffness

Range (kN)	Stiffness (N/m)
7.5	5.0×10^8
10	6.7×10^8
15	1.0×10^9
25	1.7×10^9
50	3.3×10^9

Notes

- AL = Applied load.
- RL = Rated load.
- Temperature coefficients apply over the compensated range.
- The load must be applied directly through the central loading axis.

Connections

The loadcell is fitted with 2 metres of PVC insulated 4 core screened cable type 7-2-4C.

Excitation + = Red, Excitation - = Blue, Signal + = Yellow, Signal - = Green, Screen = Orange.

The screen is not connected to the loadcell body.